

User Guide

Revision 1.0

June 2025

UPAS Outdoor Enclosure



**ACCESS SENSOR
TECHNOLOGIES**

Sampling made simple.®

Notices

© Access Sensor Technologies LLC, 2025

No part of this manual may be reproduced in any form or by any means (including electronic storage and retrieval or translation into a foreign language) without prior agreement and written consent from Access Sensor Technologies as governed by United States and international copyright laws.

Revision:

Revision 1.0, June 2025

Published by:

Access Sensor Technologies LLC, Fort Collins, CO, USA

Technical Support:

<https://www.accsensors.com/>
support@accsenors.com

Contents

- Abbreviations 4
- 1 Overview 5
 - Components included with the UPAS Outdoor Enclosure 6
 - Optional add-on components for the UPAS Outdoor Enclosure..... 6
 - Component descriptions 7
 - Outdoor enclosure 7
 - Standard mounting bracket 8
 - Line power adapter 8
 - External battery 9
 - Cooling fan..... 9
 - Small solar panel 11
 - Large solar panel and large solar bracket 11
- 2 Installing a UPAS in the enclosure..... 12
- 3 Using a Voltaic external battery..... 14
 - Installing the battery in the UPAS Outdoor Enclosure 14
 - Charging the external battery..... 15
 - Temperature limits..... 16
- 4 Programming the UPAS 17

Abbreviations

Abbreviations used throughout this manual are defined below in alphabetical order:

AST	Access Sensor Technologies
BLE	Bluetooth low energy
GPS	Global Positioning System
LED	light-emitting diode
PM	particulate matter
SOC	state of charge
PTFE	polytetrafluoroethylene (Teflon™)
UPAS	Ultrasonic Personal Air Sampler
U.S.	United States
VAC	Volts Alternating Current
VDC	Volts Direct Current

1 Overview

The Outdoor Enclosure is designed to house and protect a UPAS v2.0, v2.1, or v2.1 PLUS in outdoor environments (**Figure 1**). The Outdoor Enclosure can also be configured to provide power to the UPAS from a 110-240 VAC electrical outlet, external battery, or solar panel. Read the UPAS v2.1 and v2.1 PLUS User Guide to become familiar with UPAS operation before using the Outdoor Enclosure.

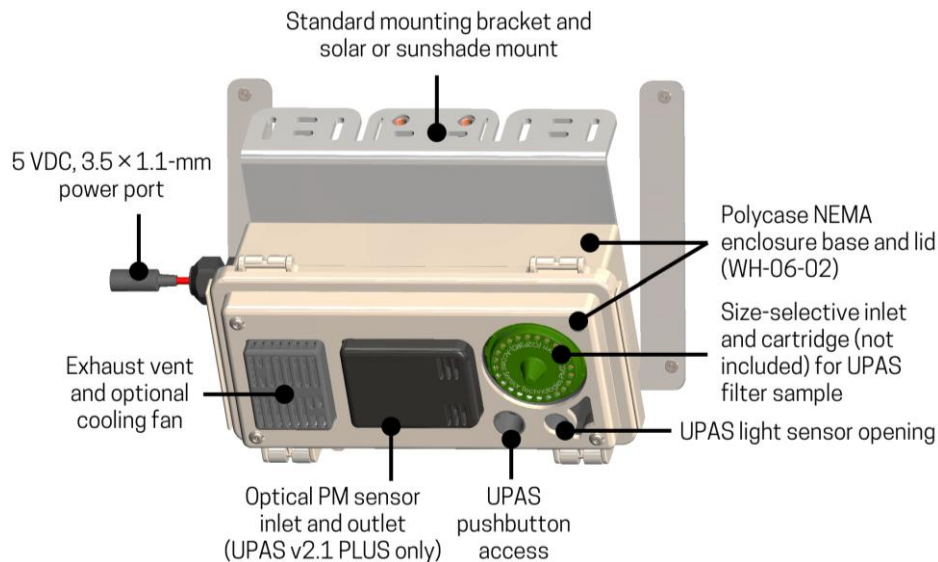

Figure 1. Main external features of the UPAS Outdoor Enclosure. The enclosure is shown here with our standard mounting bracket attached, with a UPAS v2.1 PLUS installed, and with a $PM_{2.5} 2 L min^{-1}$ inlet installed on the UPAS. Mounting brackets, UPAS, and size-selective inlets must be purchased separately.



IMPORTANT! The Outdoor Enclosure will only protect the UPAS and associated electronics from water ingress when oriented so that the enclosure lid and UPAS inlet face the ground (see **Figure 2**). The Outdoor Enclosure will not protect the UPAS from precipitation that falls on the UPAS inlets directly or from water that is sprayed at the UPAS inlets directly.

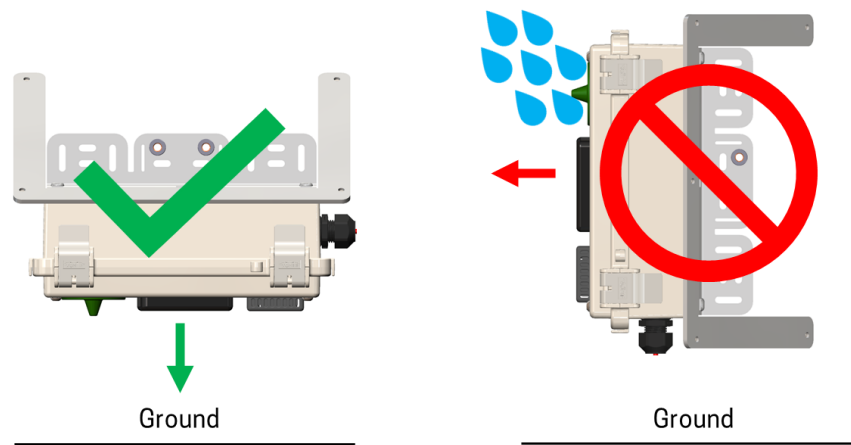

Figure 2. Left: Mount the Outdoor Enclosure with the lid and UPAS inlet facing the ground to protect the UPAS and associated electronics from water damage. Right: Do *not* mount the enclosure with the UPAS inlet facing away from the ground; in this orientation, the UPAS and associated electronics could experience water damage.



IMPORTANT! Only use electronic charging hardware provided by AST with the Outdoor Enclosure and UPAS. The charging hardware included with the enclosure is tested for compatibility and ensures the device and charging system are protected while operating.

Components included with the UPAS Outdoor Enclosure

Item description	Part number	Application
Outdoor enclosure	Polycase WH-06-02 with custom machining	NEMA enclosure to house and protect UPAS and other electronics
Phillips thread-forming screws (×4)	Polycase SCREWS-032-50	Secure the enclosure to the standard mounting bracket or other interface
5 VDC weatherproof power port passthrough	AST custom assembly	Allows electrical connection to line power adapter or solar panel for charging

Optional add-on components for the UPAS Outdoor Enclosure

Item description	Part number	Application
Standard mounting bracket	AST custom part	Connects to the Outdoor Enclosure to facilitate mounting and sunshade or solar panel attachment.
Line power adapter	AST custom assembly	Connect the UPAS and Outdoor Enclosure to 110-240 VAC line power from an electrical outlet.
External battery	Voltaic V75 (V50 and V25 not sold by AST)	Charge the UPAS from an external battery to extend sample runtime.
Cooling fan	AST custom assembly	Help cool the inside of the Outdoor Enclosure. ^{1,2}
Sunshade	AST custom part (274 × 200 mm; UV-resistant acrylic)	Shield the Outdoor Enclosure from direct sunlight to reduce heating of components inside the enclosure.
Small solar panel	Voltaic P110 (10 W, 6 V)	Charge the Voltaic external battery using solar power to extend the UPAS sample runtime. ^{3,4}
Large solar panel and extra-large mounting bracket	Voltaic P120 (20 W, 6 V) and BK108	Charge the Voltaic external battery using solar power to extend the UPAS sample runtime. ^{3,5}

1. The cooling fan requires an external power source. The cooling fan will run off the same power source as the UPAS (either line power or the Voltaic external battery pack).
2. Do not use the cooling fan when collecting UPAS filter samples using a duty cycle of less than 100%.
3. Requires installation of Voltaic V75 (or V50 or V25) external battery in the Outdoor Enclosure.
4. The Voltaic P110 10-Watt solar panel connects to the standard mounting bracket. The panel plug connects to the 5VDC power port on the UPAS Outdoor Enclosure.
5. Voltaic P120 solar panel and BK108 mounting bracket are pre-assembled together and connected to our standard mounting bracket. The plug on the P120 panel connects to the 5 VDC power port on the UPAS Outdoor Enclosure. Screw hardware, an M6 driver, and 10-mm wrench are included.

Component descriptions

Outdoor enclosure

The UPAS Outdoor Enclosure is a customized [Polycase WH-06-02 NEMA enclosure](#). This enclosure features a hinged lid, two latching clasps, and a padlock hasp. The inside of the enclosure (**Figure 3**) features mounting locations and Velcro straps that can be used to secure a UPAS as well as an optional Voltaic USB battery pack (V75, V50, or V25 batteries sold before November 2025).

When a UPAS is installed in the Outdoor Enclosure and the lid is open, the user can access the micro-USB port and microSD card on the UPAS.

When a UPAS is installed in the Outdoor Enclosure and the lid is closed:

- Our GEN2 size-selective inlets and filter cartridges can be installed on and removed from the UPAS without opening the enclosure.
- A flow check adapter can be installed over any GEN2 size-selective inlet that is installed on the UPAS so that the sample flow rate can be verified against an external flow rate meter.
- The UPAS inlet has unrestricted contact with the ambient air for sampling.
- The UPAS mounting insert and vents are designed to prevent air that has already been sampled by the UPAS (i.e., clean air downstream of the sample filter) from being re-sampled.
- The user has access to the UPAS pushbutton.
- The UPAS light sensor can see ambient light through an opening in the lid.
- Neither the UPAS microSD card nor any external battery pack that is installed are visible or accessible from the outside of the UPAS Outdoor Enclosure.

The base of the Outdoor Enclosure features a 5 VDC power port that can be used to connect an external power source. Using this port and the appropriate adapter cables, line power from an electrical outlet can be connected to the UPAS directly or a solar panel can be connected to certain Voltaic USB battery packs. The base also features four bossed holes that can be used, along with the included #8-16 × 0.31" thread-forming screws, to attach the enclosure to the standard mounting bracket or another mounting system (**Figure 4**). If the Outdoor Enclosure is purchased with the optional cooling fan, the fan will be installed in the lid, and the lid inlet vent will be unplugged, as shown in **Figure 3**.

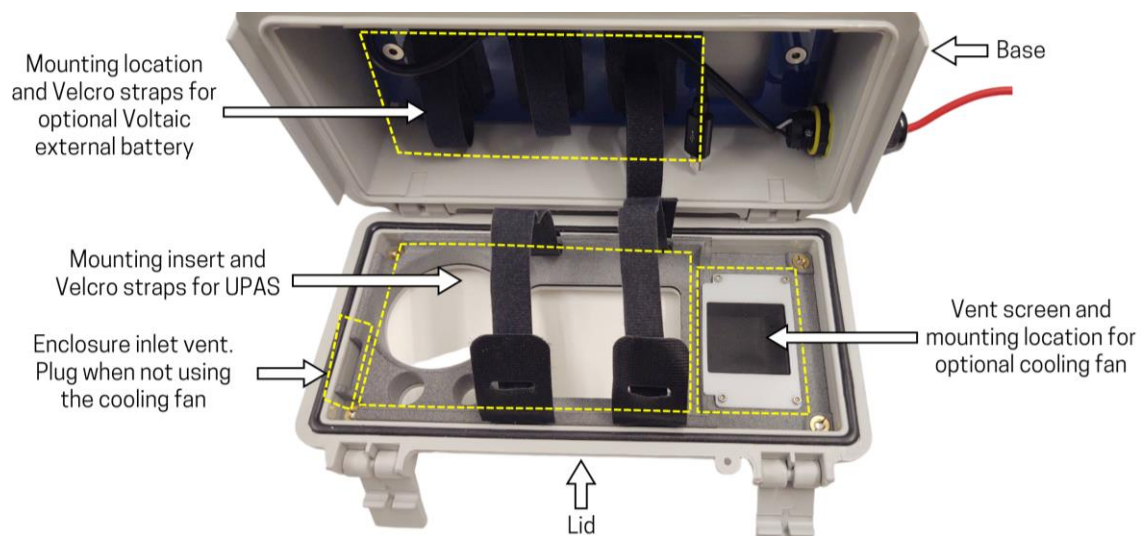

Figure 3. View of the inside of the UPAS Outdoor Enclosure with key features labeled.

Standard mounting bracket

The standard mounting bracket is designed to make it easy to mount the Outdoor Enclosure at a sampling site. The slots, holes, and threaded inserts shown in **Figure 4** can be used to secure the bracket to a pole, wall, or the large solar panel bracket using worm clamps, straps, or bolts.

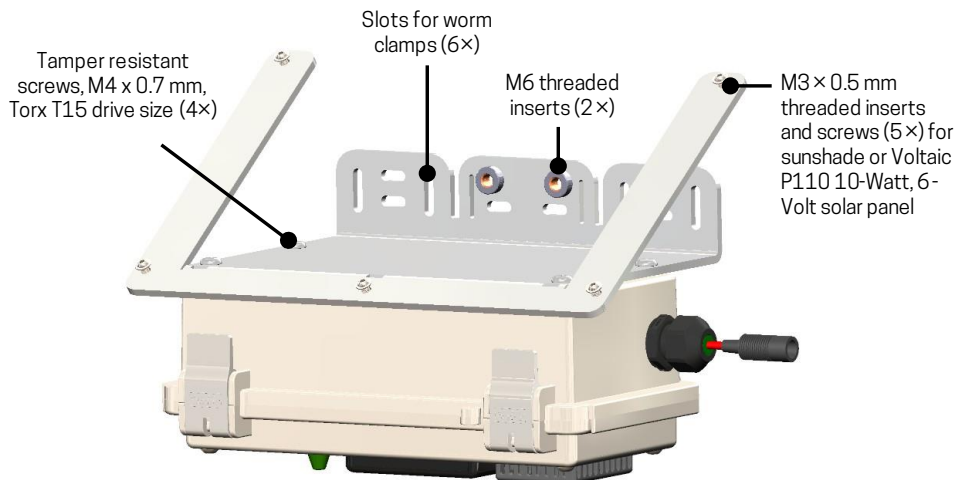

Figure 4. The standard mounting bracket attached to the UPAS Outdoor Enclosure with key features labeled.

The standard mounting bracket can be attached to the four bossed holes on the base of the Outdoor Enclosure, as shown in **Figure 4**, using four #8-16 × 0.031" Phillips thread forming screws (included).

Line power adapter

The line power adapter can be used to provide line power to a UPAS (and, optionally, a Voltaic external battery pack and/or cooling fan) that is installed in an Outdoor Enclosure (**Figure 5**). The line power adapter accepts 110-240 VAC input from an electrical outlet and converts it to a 5 VDC (and up to 4 Amp) output at the 3.5 × 1.1-mm barrel jack plug. The line power adapter is assembled by AST and facilitates safe charging and operation of electronics installed in a UPAS Outdoor Enclosure. To avoid damaging your product(s), use only the line power adapter provided by AST with the Outdoor Enclosure.

Connect the barrel jack plug on the line power adapter to the 5 VDC power port on the UPAS Outdoor Enclosure. Make sure the plug and port snap together and do not pull apart easily. Inside the enclosure, the 5 VDC external power port is connected to a USB-C charging cable. This USB-C charging cable can be connected in one of two ways depending on whether you are also using a Voltaic external battery:

- 1 When using line power with no external battery, plug the USB-C cable into a USB-C to micro-USB adapter dongle (included). Then, connect the micro-USB plug end of the dongle directly to the micro-USB port on the UPAS.
- 2 When using line power and an external battery, plug the USB-C cable into the USB-C charging port on the external battery (**Figure 6**). Then, use the included USB-A to micro-USB cable to connect the USB-A output port on the external battery to the micro-USB port on the UPAS.

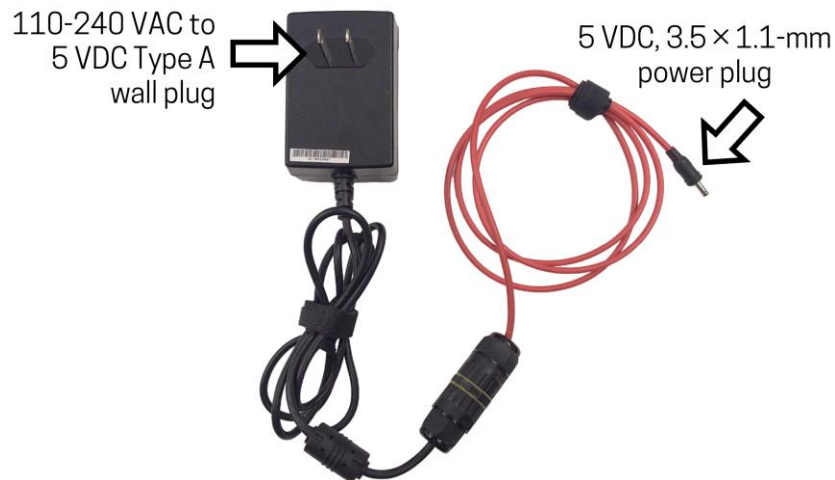

Figure 5. Line power adapter for the UPAS Outdoor Enclosure with key features labeled.

Cooling fan

An optional fan can be installed to increase airflow through the Outdoor Enclosure in an effort to limit the extent to which the interior is heated above ambient temperature. The cooling fan is recommended if the enclosure will be used in environments where the ambient temperature regularly exceeds 35 °C.

The cooling fan requires an external power source (e.g., line power, a solar panel, and/or an external battery pack). The cooling fan will be installed by AST and configured to run on the same external power source that will be used to charge the UPAS (either direct line power or a Voltaic external battery; the latter of which can be connected to line power or, depending on the battery version, a solar panel). When the cooling fan is installed, the Outdoor Enclosure lid will be configured with a screened inlet vent to help air circulate through the enclosure (see **Figure 3**). When a visible amount of dust builds up on the screens covering the inlet vent and the fan, disconnect power from the fan and wipe the screens clean using a paper towel or other cleaning cloth that has been dampened with a small amount of water or isopropyl alcohol.

IMPORTANT! If you wish to run the cooling fan while collecting a filter sample with the UPAS, only do so if the filter sample is being collected with a 100% duty cycle. If the cooling fan is running while the UPAS is collecting a filter sample with a duty cycle of less than 100%, the fan will pull in air through the UPAS inlet during the portion of the duty cycle when the UPAS pumps are off; however, the fan will *not* pull air through the inlet at the target sample volumetric flow rate when the UPAS pumps are off and, as a result, the size-selective inlet will not function as intended and the particulate matter sample will not reflect the intended size fraction.

Voltaic external battery

Some versions of Voltaic USB battery packs can be secured inside the Outdoor Enclosure and used to charge the UPAS during sampling. These battery packs can be charged using line power while the battery pack is charging the UPAS simultaneously. Some versions can also be charged using a solar panel while the battery pack is charging the UPAS simultaneously. See Section 3 to learn how to install an external battery in the Outdoor Enclosure, connect the external battery to the UPAS, and connect the external battery to line power or a solar panel.

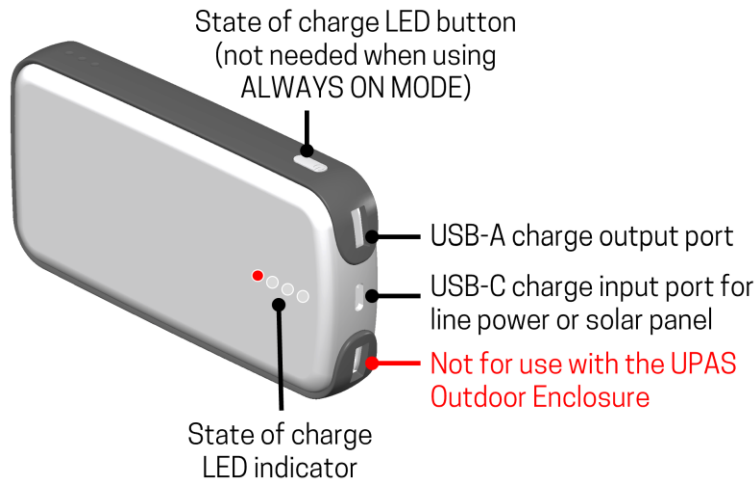

Figure 6. The first version of the Voltaic V75 external battery pack with key features labeled.

Voltaic has sold three different versions of silver V75 (71 Wh), V50 (47 Wh), and V25 (23 Wh) batteries:

1. The first version was sold by Voltaic **before February 2024**. These batteries included a single USB-C charge input port on the top end of the battery pack as shown in **Figure 6**. These batteries can accept charge from a wall outlet or solar panel (Voltaic P110 or P120) while installed in the UPAS Outdoor Enclosure. These batteries can be identified by the sixth line of text in the marking on the back of the battery: “USB C: 5-6V/2A Input” (see **Figure 7**).
2. The second version was sold by Voltaic starting February 2024 and will be available until November 2025. The USB-C solar power input port is on the side of these battery packs. These batteries *cannot* accept charge from a solar panel when installed in the Outdoor Enclosure because the side USB-C port is not accessible when the battery is in the enclosure. These batteries can still accept charge from a wall outlet through the USB-C input port on the top end while installed in the Outdoor Enclosure. These batteries can be identified by fifth line of text in the marking on the back of the battery: “Side USB C: 5-6V == 2 A Solar Input” (see **Figure 7**). Refer to this [blog post from Voltaic](#) for more information on these batteries.
3. The third version, which will be sold by Voltaic starting in November 2025, *will not fit in the UPAS Outdoor Enclosure*. After November 2025, the first and second versions will no longer be available for purchase.



First version

Second version

Figure 7. Markings on the back of the first and second versions of Voltaic V75 batteries.

AST sold the first version of the silver Voltaic V75 battery pack between January 2023 and June 2025. This User Guide describes how to use the first version of the V75, V50, or V25 battery pack with the UPAS Outdoor Enclosure. AST has never sold the second version of the V75, V50, or V25 batteries.

Starting June 2025, AST recommends using the [Voltaic 25-Watt CORE Solar System](#) in outdoor sampling applications that require expanded battery capacity and solar power. The CORE Solar System combines a 25-W, 18-V solar panel and a 12-V, 18-Ah (230 Wh) LiFePO4 battery with an integrated MPPT charge controller. The CORE Solar System must be purchased through Voltaic Systems; AST does not stock the CORE Solar System for sale. When ordering through Voltaic, you can request that the CORE Solar System be supplied with a 12 V to 5 V regulator and a 3.5- × 1.1-mm power plug for connection to the UPAS Outdoor Enclosure.

Small solar panel

A [Voltaic P110](#) 10-Watt, 6-Volt solar panel can be secured to the standard mounting bracket at a fixed angle using five included 8-mm-long M3 × 0.5 mm screws. The plug on the solar panel must be connected to a Voltaic external battery pack via the 5 VDC external power port on the Outdoor Enclosure. Plug the solar panel into the 5 VDC external power port; then, connect the USB-C cable on the inside of the enclosure to the USB-C charge input port on the top end of the Voltaic battery (see [Figure 6](#)). Finally, connect the USB-A charge output port on the Voltaic battery to the micro-USB port on the UPAS using the included silver USB-A to micro-USB cable.



IMPORTANT! When using a Voltaic solar panel to charge the UPAS, a Voltaic external battery pack is also required. Voltaic external battery packs have built-in charge controls for solar applications. Do not connect a solar panel directly to the UPAS for charging; doing so could damage the UPAS electronics.

Large solar panel and extra-large mounting bracket

A [Voltaic P120](#) 20-Watt, 6-Volt solar panel can also be used to charge a Voltaic external battery pack that charges the UPAS; however, this larger solar panel requires an additional, larger mounting bracket. The Voltaic P120 solar panel is pre-assembled with the extra-large [Voltaic BK108](#) mounting bracket; this assembly is subsequently connected to the standard mounting bracket using two bolts (included) through the M6 threaded inserts shown in [Figure 4](#).



IMPORTANT! When using a Voltaic solar panel to charge the UPAS, a Voltaic external battery pack is also required. Voltaic external battery packs have built-in charge controls for solar applications. Do not connect a solar panel directly to the UPAS for charging; doing so could damage the UPAS electronics.

2 Installing a UPAS in the enclosure

Follow the steps illustrated in **Figure 8** and described below to install a UPAS v2.0, v2.1 or v2.1 PLUS in the outdoor enclosure.

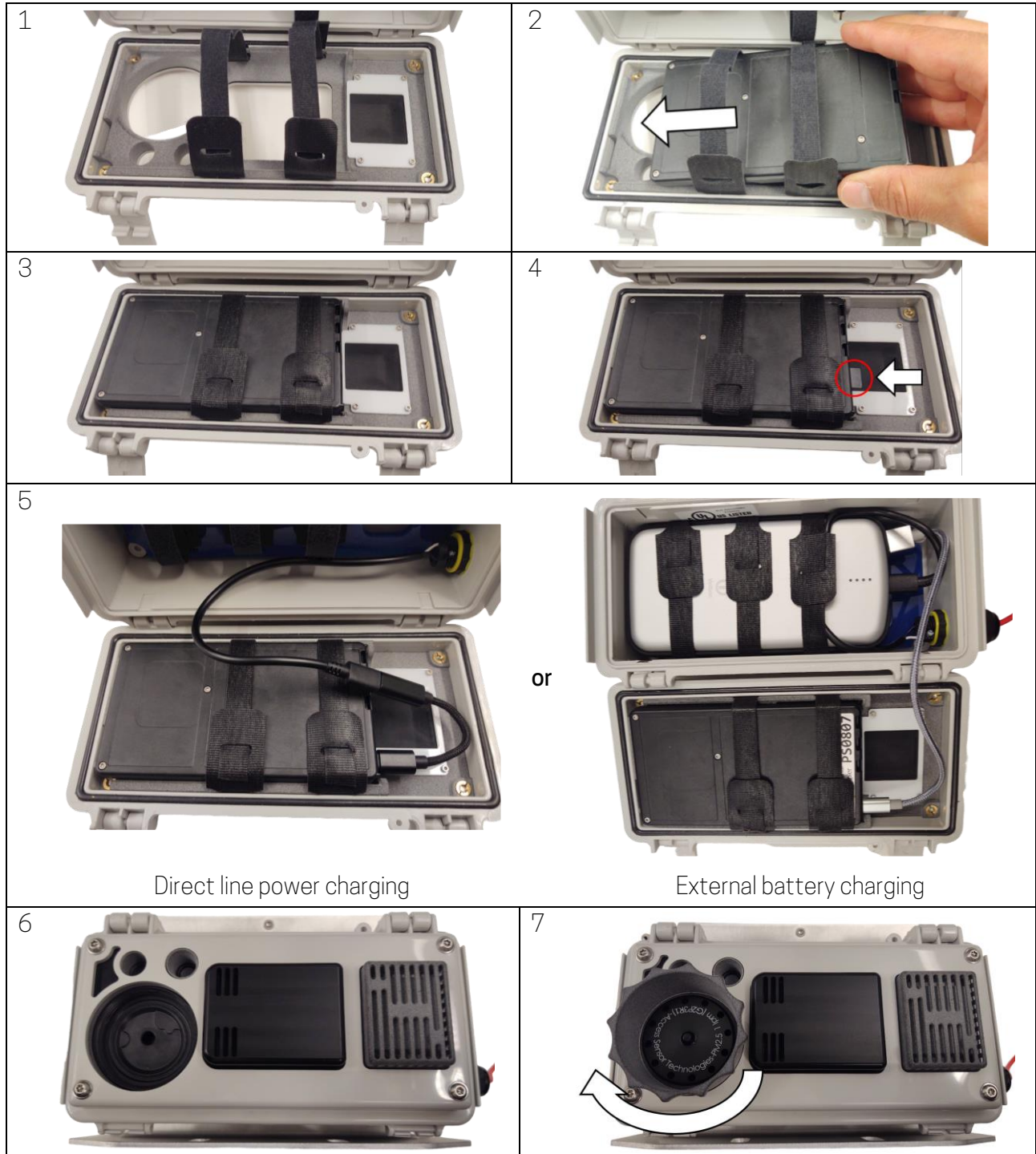

Figure 8. Follow these steps to install a UPAS in the outdoor enclosure.

- 1 Loosen the two Velcro straps inside the enclosure lid. Disconnect the narrow end of each strap from the wider tab on the opposite end and pull up on the lower band of each strap to make space for a UPAS.
- 2 Place the UPAS in the enclosure lid by sliding the UPAS under both Velcro straps and into the mounting insert. Align the round UPAS inlet socket with the circular hole in the lid.
- 3 Pull the ends of each Velcro strap tight around the UPAS to secure the UPAS in the lid.
- 4 If you haven't done so already, install a microSD card in the UPAS. Locate the microSD slot on the bottom of the UPAS and insert the card so that the metal connection pads are facing up (white side down) when you are looking at the UPAS as installed in the lid. Gently push the card in with a coin, paper clip, ballpoint pen tip, or your fingernail until you feel it click into place; then, release the microSD card. The microSD card should remain inside the UPAS housing when released.
- 5 When applicable, connect your external power source to the micro-USB port on the UPAS.

Direct line power charging: To charge the UPAS internal battery directly using line power, use the USB-C to micro-USB adapter dongle to connect the USB-C cable on the inside of the UPAS Outdoor Enclosure to the micro-USB port on the UPAS.

External battery charging: To charge the UPAS using a Voltaic external battery pack (regardless of whether the Voltaic battery pack will be charged using line power or a solar panel), use the silver USB-A to micro-USB cable to connect the USB-A charge output port on the Voltaic battery to the micro-USB port on the UPAS. Do not connect a solar panel directly to a UPAS for charging. A solar panel must always be used in conjunction with a Voltaic external battery pack (see Section **Error! Reference source not found.**). The solar panel can be used to charge the Voltaic battery and the Voltaic battery can be used, in turn, to charge the UPAS.

- 6 Close the enclosure. Check that no cables will get pinched between the enclosure lid and base; then, press the lid against the base of the enclosure and snap down the two latches.
- 7 Install an UPAS-compatible sample filter, GEN2 filter cartridge, and GEN2 size-selective inlet on the UPAS. Tighten the inlet assembly by placing an inlet tool over the inlet and turning the tool clockwise.

3 Using a Voltaic external battery

Voltaic V75, V50, or V25 batteries sold before November 2025 can be installed in the Outdoor Enclosure to charge the UPAS (with or without line power or a solar panel to charge the Voltaic battery; see **Figure 9**). Refer to the [Voltaic Systems V25 - V50 - V75 Instruction Booklet](#) for more details on how to operate, charge, and store these battery packs.



Figure 9. Voltaic Systems V75, V50, and V25 battery packs installed in the Outdoor Enclosure. These batteries are shown with the black USB-C cable connected to the USB-C charge input port on the top end of the battery (to charge the external battery pack) and a silver USB-A to micro-USB cable connected to the USB-A charge output port on the battery.

Installing the battery in the UPAS Outdoor Enclosure

Follow the steps described below and illustrated in **Figure 10** to install a Voltaic V75 battery in the UPAS Outdoor Enclosure and connect it to the UPAS.



Disconnect the outdoor enclosure 5 VDC external power port from all power sources before installing or removing the external battery.

- 1 Locate the three Velcro straps that are attached to the blue mounting panel inside the enclosure base. Disconnect the narrow end of each strap from the wider tab on the opposite end while leaving the straps attached to the panel.
- 2 Orient the Voltaic battery so that the state-of-charge LEDs face out (such that the LEDs remain visible to you) and the top end of the battery with three USB ports faces the end of the enclosure where the 5 VDC external power port passthrough is located. Hold the straps aside to keep them accessible and place the external battery in the base of the enclosure while keeping the top end with three ports tilted up.
- 3 Plug the USB-A end of the silver USB-A to micro-USB cable into the USB-A charge output port on the Voltaic battery. If the Voltaic battery will be charged using line power or a solar panel, connect the USB-C cable on the inside the enclosure to the USB-C charge input port on the Voltaic battery. (Note: The ports on the Voltaic battery are illustrated and labeled in **Figure 6**.)
- 4 Lower the end of the Voltaic battery with the three USB ports into the enclosure while bending the USB cables up as needed (a snug fit is expected with the Voltaic V75). Tighten the three Velcro straps around the Voltaic battery to secure the battery to the blue mounting panel.
- 5 Plug the micro-USB end of the silver cable into the micro-USB port on the UPAS.

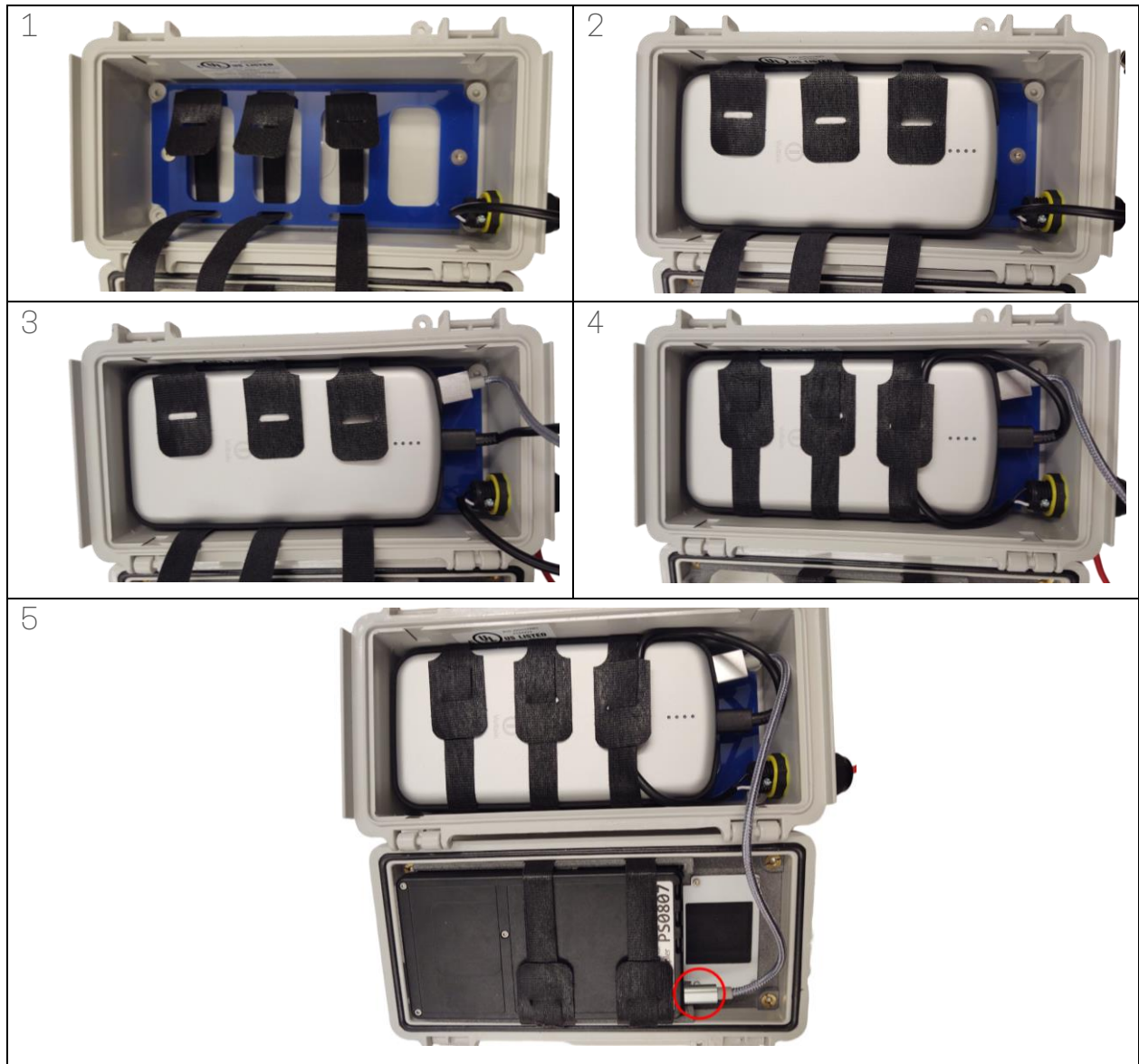

Figure 10. Follow these steps to install a Voltaic V75 battery in the UPAS Outdoor Enclosure.

Charging the external battery

There are three ways to charge a Voltaic battery that you intend to use with the Outdoor Enclosure:

- 1 **Using line power:** Remove the Voltaic battery from the UPAS Outdoor Enclosure and charge the battery using line power, a 5 V power adapter specified by Voltaic Systems, and a charging cable specified by Voltaic Systems. If you purchase a V75 battery from AST, we will include the charging cable provided by Voltaic Systems.
- 2 **Using line power:** While the Voltaic battery is installed in the UPAS Outdoor Enclosure, connect the USB-C charging cable on the inside of the enclosure to the USB-C charge input port on the top end of the battery (see **Figure 6**) and then connect the 5 VDC external power port on the enclosure (see **Figure 1**) to an electrical outlet using the line power adapter (**Figure 5**).

- 3 **Using a solar panel:** While the Voltaic battery is installed in the UPAS Outdoor Enclosure, connect the USB-C charging cable on the inside of the enclosure to the USB-C charge input port on the top end battery (see **Figure 6**) and then connect the 5 VDC external power port on the enclosure (see **Figure 1**) to a solar panel. Note that only the first version of Voltaic V75, V50, and V25 batteries—which were sold by Voltaic before February 2024 and sold by AST until June 2025—can be charged using a solar panel while installed in the Outdoor Enclosure.

Temperature limits

Voltaic Systems V75, V50, and V25 battery packs can charge at temperatures between 0 and 45 °C. Consider how this temperature range compares to the temperatures you expect the UPAS Outdoor Enclosure to be exposed to at your sampling site. The temperature inside the UPAS Outdoor Enclosure can be up to 10 °C warmer than the ambient temperature due to heat generated by the UPAS and other electronics inside the enclosure; as a result, if the ambient temperature exceeds 35 °C (95 °F), the Voltaic battery might sense a temperature above 45 °C and stop accepting charge from your line power source or solar panel. Before you start a sampling campaign, we recommend that you test your UPAS, Outdoor Enclosure, Voltaic battery pack, and solar panel setup in the ambient conditions you expect the system to be exposed to during sampling.

4 Programming the UPAS

If you are using a UPAS v2.1 or v2.1 PLUS, we strongly recommend reading Section 4 of the UPAS v2.1 and v2.1 PLUS User Guide for more detailed information on sample programming. If you are using a UPAS v2.0, we strongly recommend reading Section 3 of the UPAS v2.0 User Manual (published June 2018) for more detailed information on sample programming.

- 1 Turn the UPAS on by pressing and holding down the UPAS pushbutton for at least 3 seconds until the pushbutton LED lights up.
- 2 Wait until the UPAS is ready to connect to the mobile app. A UPAS v2.1 or v2.1 PLUS that has firmware version ≥ 200 installed is ready to connect when the pushbutton LED is flashing or solid **pink**. A UPAS v2.0 or a UPAS v2.1/v2.1 PLUS running firmware version < 200 is ready to connect only when the pushbutton LED is solid **pink**.

If you are using a UPAS v2.1 or v2.1 PLUS and the UPAS is not in “external power mode,” the UPAS will not become ready to connect to the app while connected to external power (i.e., line power or an external battery pack). Similarly, if you are using an UPAS v2.0, the UPAS will not become ready to connect to the app while connected to external power (and there is no external power mode available for the UPAS v2.0). If the UPAS is connected to external power and the LED keeps flashing **blue** instead of turning **pink**, you will need to disconnect the external power source from the UPAS micro-USB port and then wait for the UPAS to become ready to connect to the app. If you are using a using a UPAS v2.1 or v2.1 PLUS, you can put the UPAS into external power mode later during the programming process so that, in the future, the UPAS will be able to connect to the app while connected to external power.

- 3 Ensure that Bluetooth is enabled on the mobile device you will use to program the UPAS.
- 4 Open the appropriate mobile device app for your UPAS. If you’re using a UPAS v2.1 or v2.1 PLUS, use the AST UPAS app. If you’re using a UPAS v2.0, use the CSU UPAS app.
- 5 Scan and connect to the UPAS with the app.

In the AST UPAS app: Select “Click to connect to a sampler.” The app will direct to a new screen and start scanning for UPAS automatically.

In the CSU UPAS app: Select “Connection Status: Disconnected.” The app will direct to a new screen. This app will not start scanning automatically. You will need to hit the “SCAN” button in the upper right-hand corner to scan for a UPAS.

If the serial ID of the UPAS you are looking for does not appear on the screen, hit the “scan” button in the upper right-hand corner of the screen to re-scan for the UPAS.

- 6 Select the UPAS serial ID to pair the UPAS with the app.

If multiple UPAS are available to connect, multiple serial IDs will appear on the screen, but the app can only connect to one UPAS at a time.

When the UPAS has paired with the app, the UPAS Serial ID will appear on the “Connection Status” line in the Main Menu. Additionally, if the UPAS pushbutton LED was solid **pink** before

pairing, it will turn solid **blue** once paired. If the UPAS pushbutton LED was flashing **pink** before pairing, it will alternate between **blue** and **pink** flashes once paired.

- 7 If you are: (a) using a UPAS v2.1 or v2.1 PLUS, (b) charging that UPAS during sampling with an external power source (line power, an external battery, or an external battery pack that is connected to a solar panel), and (c) the UPAS is not yet in external power mode, put the UPAS into external power mode by selecting the "Sample Name" field, entering **EXTPOW#** as the sample name, then hitting "return" on an iOS device or "Ok" on an Android device. At that point, the app will return to the main menu and **EXTPOW#** will disappear from the Sample Name field and the mode will be activated. In the future, the UPAS will be able to connect to the mobile app regardless of whether the UPAS is connected to external power.

NOTE: It's okay to complete this step even if you're not sure whether your UPAS v2.1 or v2.1 PLUS is in external power mode. Performing this step will have no effect if the UPAS is already in external power mode. A different code is used to turn external power mode off. See the UPAS v2.1 and v2.1 PLUS User Guide for additional information.

- 8 Program your desired sample settings using the app. See the UPAS v2.1 and v2.1 PLUS User Guide or the UPAS v2.0 User Manual for additional information on how to program the UPAS.



**ACCESS SENSOR
TECHNOLOGIES**
Sampling made simple.®

Revision 1.0
June 2025
<https://www.accsensors.com>