

Revised PM_{2.5} 1 LPM cyclone inlet design

Access Sensor Technologies has improved the design of our PM_{2.5} 1 LPM cyclone inlet to achieve a penetration efficiency that aligns more closely with the United States Environmental Protection Agency (US EPA) definition of PM_{2.5} (Figure 1).

Recent tests indicated that the old (R0) design had a cutpoint (d_{50}) that was closer to 3.0 μm than to 2.5 μm .

Questions you might have:

“How would the difference between the old and new inlet designs affect samples collected with the UPAS?”

“How will the change from the old to new design affect my measurements moving forward?”

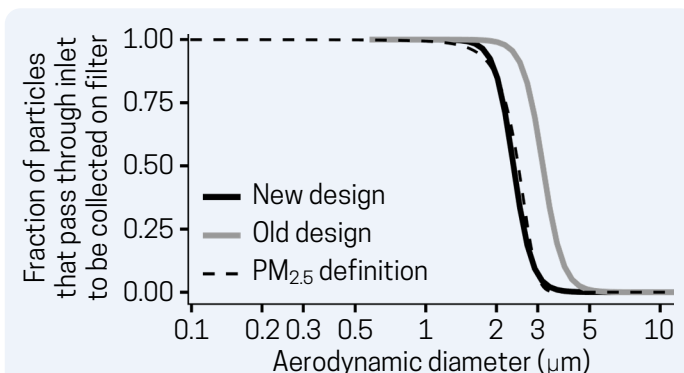
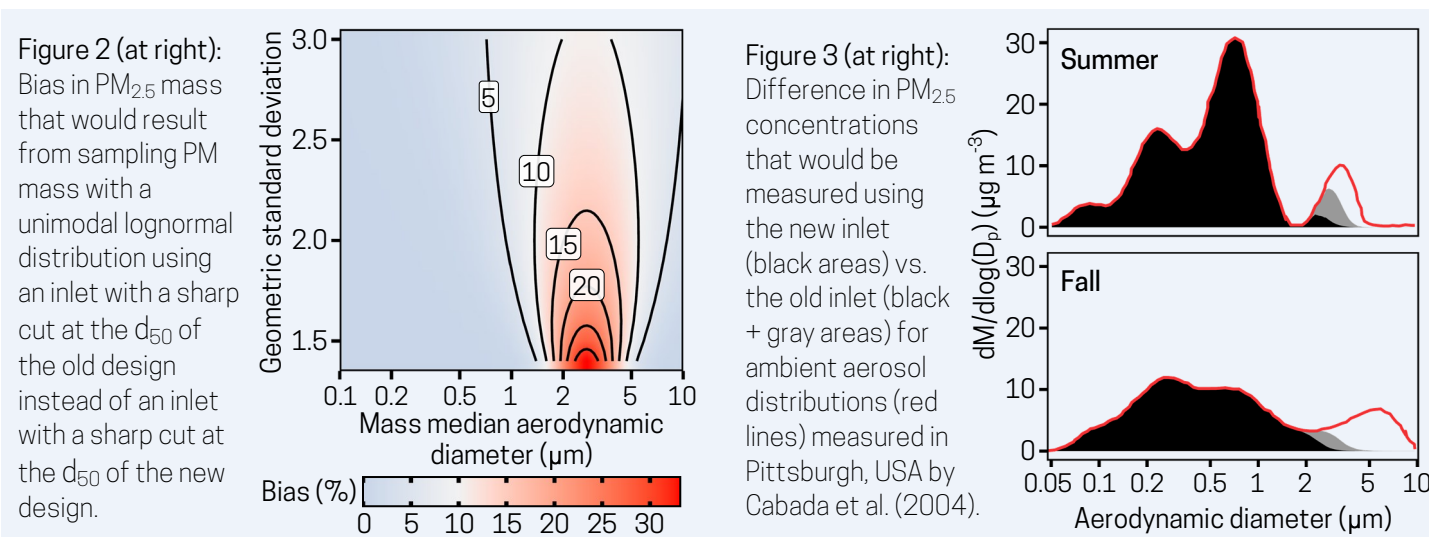

Figure 1: Penetration efficiency vs. aerodynamic diameter for the new (R1) and old (R0) PM_{2.5} 1 LPM cyclone inlet designs compared to the US EPA definition of PM_{2.5}.

In most situations, we expect the difference in mass sampled using the old versus new PM_{2.5} 1 LPM inlet to be small; see Figure 2 for more information. Additionally, consider the following real-world examples:

The difference in mass sampled using the old vs. new inlet would be 4% for the seasonally-averaged ambient aerosol mass distributions measured during both summer and fall in Pittsburgh, USA by Cabada et al. (2004; DOI: [10.1016/j.atmosenv.2004.03.004](https://doi.org/10.1016/j.atmosenv.2004.03.004); Figure 3). This difference would range from 3% to 9% for the ambient aerosol mass distributions measured in Newark, NJ, USA by Zhao and Gao (2008; DOI: [10.1016/j.atmosenv.2008.01.032](https://doi.org/10.1016/j.atmosenv.2008.01.032)).

Household air pollution from solid fuel combustion has been reported to have a unimodal distribution with a mass median diameter \approx 0.3 μm and a geometric standard deviation \approx 1.7–1.8 (Just et al., DOI: [10.1021/es304351p](https://doi.org/10.1021/es304351p)). For such a distribution, the difference in mass sampled using the old vs. new inlet would be less than 1%.



The examples above illustrate why studies that validated UPAS with the old (R0) PM_{2.5} 1 LPM inlet against other PM_{2.5} inlets that are commonly used for personal sampling (e.g., Harvard Impactor, BGI Triplex cyclone) found negligible differences in performance. For more information, see:

- Figure 5 in Arku et al. (2018) DOI: [10.1016/j.envint.2018.02.033](https://doi.org/10.1016/j.envint.2018.02.033)
- Figure 2 in Pillarisetti et al. (2019) DOI: [10.1016/j.envint.2018.11.014](https://doi.org/10.1016/j.envint.2018.11.014)
- Figure 2 in Burrowes et al. (2020) DOI: [10.1111/ina.12638](https://doi.org/10.1111/ina.12638)

ADDITIONAL QUESTIONS YOU MIGHT HAVE:

Which PM_{2.5} 1 LPM inlets will be available for purchase moving forward?

Moving forward, only the new PM_{2.5} 1 LPM inlet design will be available for purchase.

How will I know which PM_{2.5} 1 LPM inlet design I am using?

Compare the bottom side of the inlet, paying special attention to any text engraved there, to Figure 4 and Table 1.

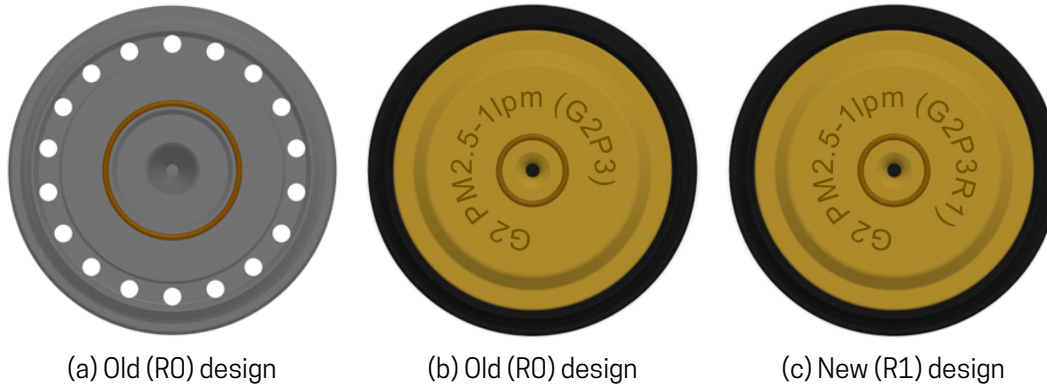

Figure 4. Compare plastic insert on the bottom side of your PM_{2.5} 1 LPM inlet to these images to determine whether the inlet uses the old (R0) or new (R1) PM_{2.5} 1 LPM cyclone design.

Table 1. Compare the plastic insert on the bottom side of your PM_{2.5} 1 LPM inlet to this table to determine whether the inlet uses the old (R0) or new (R1) PM_{2.5} 1 LPM cyclone design.

Image in Figure 4	Insert plastic color	Engraved text	PM _{2.5} cyclone design	Penetration efficiency in Figure 1
(a)	Black (opaque)	None	Old (R0)	Solid gray line
(b)	Brown (translucent)	“GEN2P3”	Old (R0)	Solid gray line
(c)	Brown (translucent)	“GEN2P3R1”	New (R1)	Solid black line

NOTE: For GEN2P3 inlets, the engraving on the top side of the black aluminum cap might differ from the engraving on the bottom side of the brown plastic insert. For example, the cap might be engraved with “GEN2P3R0” and the insert might be engraved with “GEN2P3R1”. Such a discrepancy does not indicate a problem. The design change discussed in this technical bulletin affects the plastic insert; therefore, the engraved text on the bottom of the plastic insert is what indicates whether the inlet uses the old or new PM_{2.5} 1 LPM cyclone design. GEN2P3R1 inserts, which feature the new design, are compatible with all GEN2P3 caps.

What if I am using the PM_{2.5} 2 LPM inlet?

Our PM_{2.5} 2 LPM inlet is not affected by this change. Data collected by Access Sensor Technologies in April 2024 indicates that our PM_{2.5} 2 LPM inlet performs in accordance with the US EPA definition of PM_{2.5}. See our Size-Selective Inlet Product Information Sheet or Size-Selective Inlet User Guide for performance data.